

AGL FLAIL MOWER VERGE/SIDE ARM/DITCH BANK



FHM

FARMER-HELPER MACHINERY COMPANY



OPERATION & PARTS MANUAL

**Please read these instructions carefully before using!
Always grease all fittings and be sure to always check and fill
with oil before operating! Retain this manual for future
reference. Uses Approximately 1 quart 80-90 gear lube.**

GREASE ALL FITTINGS BEFORE OPERATING!

www.Betstco.com

BETSTCO

Toll Free: 877-876-7895, E-mail: sales@betstco.com
83371 Melton Rd, Creswell OR 97426



RUGGED LABOR SAVING EQUIPMENT SINCE 1995

Specifications subject to change without notice.

Contents

Precautions	3
Decals	7
Specifications	10
Operation	12
Maintenance	16
Troubleshooting	19
Parts List	20
Parts Request Form	26
LIMITED WARRANTY	27
REGISTRATION	28

CHAPTER 1. SAFETY PRECAUTIONS



Before operating the Flail Mower read the following safety instructions. Failure to comply with these warnings may result in serious injury or death.

CONGRATULATIONS! On the purchase of your new Farmer-Helper Flail Mower. This information is to assist you in preparing, operating and maintaining your flail mower. Please read and understand the information completely before operating your mower, paying special attention to all the safety details. Keep this manual handy for a ready reference.

1.1 SAFETY FIRST

YOU are responsible for the SAFE operation and maintenance of your Flail mower. YOU must ensure that you and anyone else who is going to operate, maintain or work around the Flail mower is familiar with the operating and maintenance procedures and related SAFETY information contained in this manual. This manual will take you step-by-step through your working day and alert you to all good safety practices that should be adhered to while operating the Flail mower.

Remember, YOU are the key to safety. Good safety practices not only protect you but also the people around you. Make these practices a working part of your safety program. Be certain that EVERYONE operating this equipment is familiar with the recommended operating and maintenance procedures and follows all the safety precautions. Most accidents can be prevented. Do not risk injury or death by ignoring good safety practices.

- 1 Flail mower owners must give operating instructions to operators or employees before allowing them to operate the machine.
- 2 The most important safety feature on this equipment is a SAFE operator. It is the operator's responsibility to read and understand ALL Safety and Operating instructions in the manual and to follow these. All accidents can be avoided.
- 3 A person who has not read and understood all operating and safety instructions is not qualified to operate the machine. An untrained operator jeopardise himself and bystanders to possible serious injury or death.
- 4 Do not modify the equipment in any way. Unauthorized modification may weaken the function and/or safety and could affect the life of the equipment.
- 5 Think SAFETY! Work SAFELY!

1.2 GENERAL SAFETY

1. Read the operator's Manual and all safety signs carefully before operating, maintaining, adjusting or removing the Flail mower.
2. Do not allow passengers to ride on the Flail mower
3. Operate only at safe distance from bystanders. Clear the area of people, especially small children, before starting.
4. Stop PTO before dismounting tractor.
5. Keep feet and hands from under Flail mower at all times.
6. Keep all shields in place. If shield removal becomes necessary for repairs, replace the shield prior to use.

CHAPTER 1. SAFETY PRECAUTIONS

7. Do not stay between the tractor and the Flail Mower.
8. Do not approach the Flail mower until all motion has stopped.
9. All rotary blades have the ability to discharge objects at high speeds, which could result in serious injury to bystanders or passers-by, use with extreme caution.
10. Place all controls in neutral, stop tractor engine, set park brake, remove ignition key and wait for all moving parts to stop before servicing, adjusting, repairing, attaching or removing.
11. Review safety related items annually with all personnel who will operate or maintain the Flail mower.
12. Do not operate machine if you feel unwell or physically unfit, in which case you should stop working.
13. This machine was designed with safety very much in mind. However, there is no real substitute for caution and attention in preventing accidents. Once an accident has happened, it is too late to think about what you should have done.
14. Use a tractor equipped with a Roll Over Protective Structure (ROPS). Always wear your seat belt. Serious injury or even death could result from falling off the tractor – particularly during a turnover when the operator could be pinned under the ROPS or the tractor.
15. Never exceed the limits of a piece of machinery. If its ability to do a job, or to do so safely, is in question – **DON'T TRY IT.**
16. Clear working area of stones, branches or hidden obstacles that might be hooked or snagged, causing injury or damage.

1.3 OPERATING SAFETY

1. Read and understand the Operator's Manual and all safety signs before operating, servicing, adjusting, repairing or removing.
2. Do not allow riders.
3. Install and secure all guards and shields before starting or operating.
4. Keep hands, feet, hair and clothing away from moving parts.
5. Place all controls in neutral, stop tractor engine, set park brake, remove ignition key and wait for all moving parts to stop before servicing, adjusting, repairing, attaching or removing.
6. Place all tractor and machine controls in neutral before starting.
7. Never start or operate machine unless sitting on tractor seat.
8. Clear the area of bystanders, especially small children, before starting.
9. Stay away from PTO shaft and machine when engaging PTO. Keep others away.
10. Use warning lights on tractor when transporting.
11. Do not put hands or feet under machine while tractor engine or machine is running.
12. Do not operate Flail mower in the raised position.
13. Objects can be thrown out from under machine with sufficient force to severely injure people. Stay away from machine when it is running. Keep others away.
14. Always know what you are cutting. Never operate Flail mower in an area that has hidden obstacles. Remove sticks, stones, wire or other objects from working area before starting.
15. Review safety instructions with all operators annually.

CHAPTER 1. SAFETY PRECAUTIONS

1.4 STORAGE SAFETY

1. Store the machine in an area away from human activity.
2. Do not permit children to play on or around the stored machine.
3. Store the machine in a dry, level area.
4. Clean grease and oil as required and protect it from the elements.

1.5 MAINTENANCE SAFETY

1. Good maintenance is your responsibility. Poor maintenance is an invitation to trouble.
2. Follow good shop practices.
3. Keep service area clean and dry.
4. Be sure electrical outlets and tools are properly grounded.
5. Use adequate light for the job at hand.
6. Make sure there is plenty of ventilation. Never operate the engine of the tractor in a closed building. The exhaust fumes may cause asphyxiation.
7. Before working on this machine, shut off the engine, set the brakes, and remove the ignition key.
8. Never work under equipment unless it is secured by a mechanical stand.
9. Use personal protection devices such as eye, hand and hearing protectors, when performing any service or maintenance work. Use heavy gloves when handling blades.
10. Only use genuine parts for service and maintenance.
11. A fire extinguisher and first aid kit should be kept readily accessible while performing maintenance on this equipment.
12. Periodically tighten all bolts, nuts and screws and check that all pins are properly installed to ensure unit is in a safe condition.
13. When completing a maintenance or service function, make sure all safety shields and devices are installed before placing machine in service.

CHAPTER 1. SAFETY PRECAUTIONS

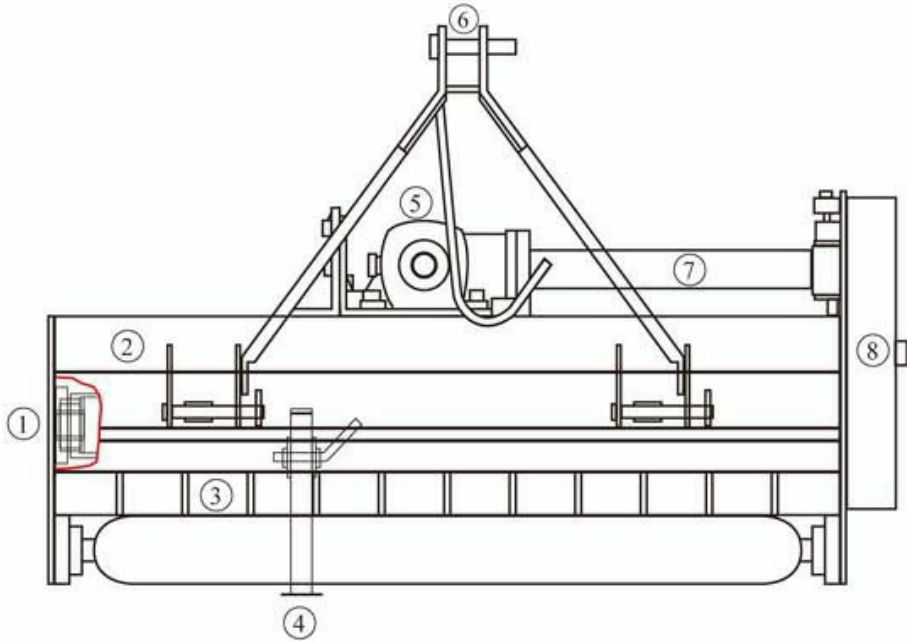

1. Blade axle	2. Blade axle cover	3. Combined fender
4. Stand	5. Gear box	6. Top Link Bracket
7. Transmission shaft	8. Belt & Pulley Cover	

PTO Shaft

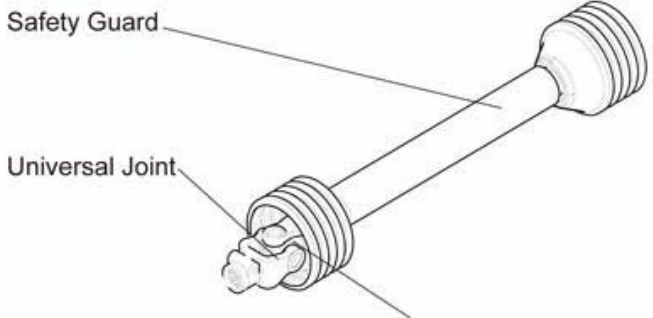

CHAPTER 2. SAFETY DECALS

SAFETY & MODEL DECAL

The position of safety decals are shown in the illustrations below. Good safety requires that you familiarize yourself with the various safety signs, and increase your **SAFETY AWARENESS**.

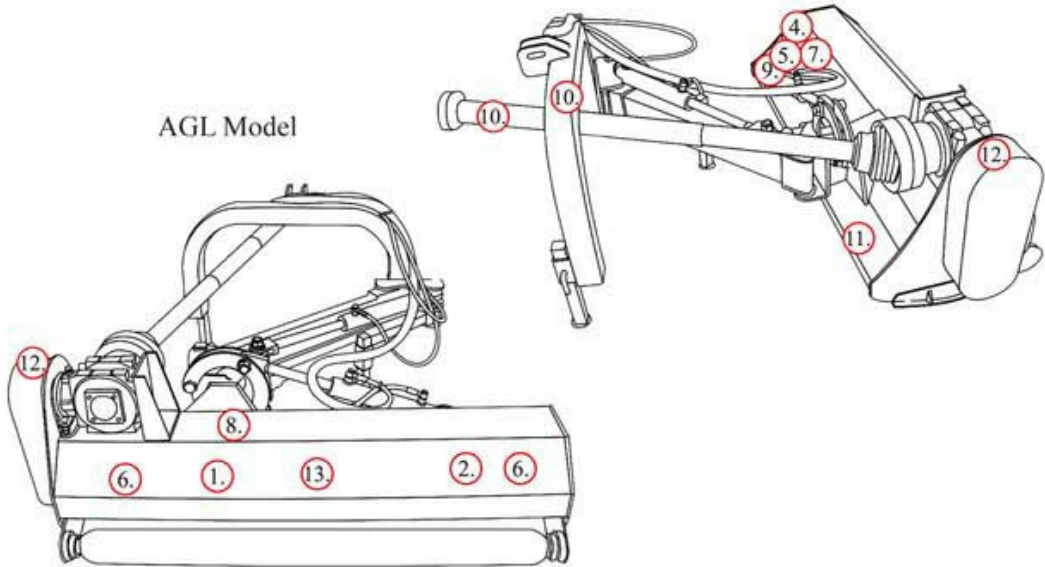

Farmer- Helper

3. 

4. 

5. 

CHAPTER 2. SAFETY DECALS

6.



7.

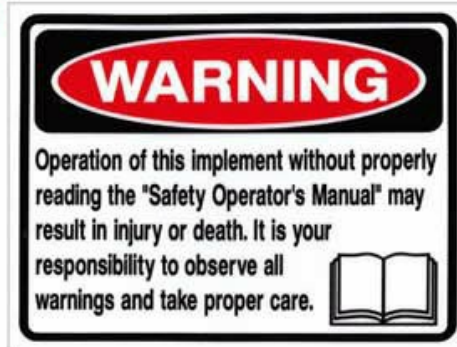

8.



9.



10.



11.



12.



13.

CHAPTER 2. SAFETY DECALS

14



15



16



CHAPTER 3. PRODUCT SPECIFICATIONS

3.1 Product No.

FLAIL MOWER MODELS

AGL Verge Hydraulic Reach Flail, Medium Duty

3.2 Implement Specifications

Farmer-Helper AGL Ditch Bank Flail Mowers Specifications			
Models	FH-AGL125	FH-AGL145	FH-AGL165
Working Width	48"	57"	65"
Overall Width	54"	63"	71"
Required HP	20Hp+	25Hp+	30Hp+
Minimum Weight Tractor & Loader	3400 lbs	4000 lbs	4600 lbs
Hitch	Cat.1	Cat.1	Cat.1
Gear Box Rating	65Hp	65Hp	65Hp
Pivot Offset*	44" Right	53" Right	61" Right
Vertical Pivot	150 Degrees	150 Degrees	150 Degrees
"Y" Grass Blades	40 Blades Installed	48 Blades Optional	56 Blades Optional
Hammer Blades	20 Hammer Blades Optional	24 Hammer Blades Installed	28 Hammer Blades Installed
Housing Thickness	1/4"	1/4"	1/4"
SidePlate Thickness	1/4"	1/4"	1/4"
Roller Dia.	4"	4"	4"
Rotor Shaft Dia.	4 1/2"	4 1/2"	4 1/2"
Blade Swing	14"	14"	14"
No. of Belts	3 Belts	3 Belts	4 Belts
3-PT. Cat-I Conn. Width	28" - 29"	28" - 29"	28" - 29"
DriveLine Type	6-Spline 62" w/ Shear Bolt	6-Spline 62" w/ Shear Bolt	6-Spline 62" w/ Shear Bolt
Warranty	2 Years	2 Years	2 Years
Weight	675lbs.	751lbs	895lbs
Shipped Weight	699lbs.	775lbs	976lbs
HYDRAULIC REQUIREMENTS - Hydraulic source must be constant flow for powering Control Valve. WE RECOMMEND use of Front Loader Style Control Valve with Float option. Float spool connected to the vertical pivoting cylinder will allow mower to float and naturally follow the ground contour. Valve, Hose, & Fittings Kit # AGL-VLVHSK			
* Total Right offset based on 54" tractor wheel width			

CHAPTER 3. PRODUCT SPECIFICATIONS

Uses:

Perfect for use after storms when debris is scattered throughout areas usually maintained with normal mowers ~ Multi-purpose machines for mulching foliage and sticks ~ ideal for thick grass, sticks, undergrowth and light vine mulching ~ vegetable & pasture topping ~ roadside maintenance.

Features:

Cutting height controlled by adjustable skids ~ high strength mulching blades ~ belt driven ~ safety flaps to prevent debris being thrown ~ extra strong and designed with safety in mind ~ support leg for storage ~ solid hitch ~FC-120/160 models include hydraulic flail catcher.

3.3 Identification of the Implement

An Identification plate is affixed to the frame of each implement. It contains the "CE" Certification brand and information about: the Manufacturer, Model, Serial Number, Year of Manufacture and Weight.

CE Identification Plate



CHAPTER 4. PRODUCT OPERATION

4.1 CHECKING BEFORE OPERATING

Before operating the machine, the following areas should be checked off:

1. Before starting up the machine, check and Lubricate all grease points, on the machine and drive shaft.
2. Use only an agricultural tractor with horsepower within limits of the implement.
3. Check that the machine is properly attached to the tractor. Be sure retainers are used on the mounting pins.
4. Be sure extra weights are mounted on the front of the tractor, if required.
5. Check the oil level in the gearbox. Add as required.
6. Check that the tractor PTO shaft turns freely and that the machine driving shaft can telescope easily.
7. Check the blades. Be sure they are not damaged or broken and swing freely in their mount. Repair or replace as required.
8. Check and tighten the blade bolts.
9. Check for entangled material in all rotating parts. Remove this material.
10. Install and secure all guards, doors and covers before starting.
11. Before installing the PTO. ensure the engine is stopped and the PTO shaft is in safe working order.
12. All other people shall leave the area before connecting the driving power from the tractor. Keep the output of the tractor at 540 RPM.
13. Before cleaning, repairing and lubricating the machine, stop the motor and take the key away with you.
14. When the PTO shaft is not connected with the tractor, support it through the frame to protect it from lying in the dirt.
15. Don't approach the machine when it is operating.

4.2 ADJUSTMENTS

ADJUSTING THE HEIGHT

To get the most out of your flail mower, it should be set within the recommended height.

To save fuel and power, and reduce wear and tear, the cutting height must be regulated correctly.

When adjusting the working height, loosen screw (1), remove screw (2) on both sides; The roller height (see following drawing) can be adjusted by aligning the selected hole in the roller support bracket at position 2. The lowest hole is the highest working height; put the screw (2) into the selected hole; tighten screw (1) and screw (2).

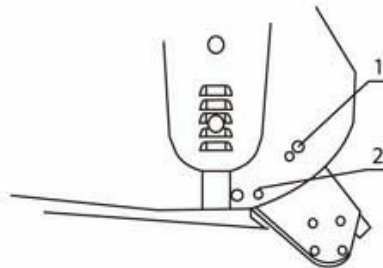

CHAPTER 4. PRODUCT OPERATION

FLAIL MOWER ADJUSTMENT

1. On a flat piece of ground, attach the Flail Mower to the Tractor using the three point linkage
2. Use a solid adjustable top link
3. Lower the three point linkage to its lowest position
4. With the roller at the rear in contact with the ground, adjust the length of the top link so that the lower edge at the side of the flail mower is parallel with the ground
5. Rotate the blade drum by hand so that a row of blades hang vertically towards the ground.
6. Measure the clearance between the bottom of the extended blades and the ground.
 - Minimum 50mm
 - Note in rough or lumpy paddocks the clearance needs to be increased to ensure that the blades dont impact the ground in operation.
7. Adjust the roller height to increase or decrease the blade clearance as required
8. Go through steps 4 to 7 until the required clearance is achieved.

When the Flail Mower has been set up with the required tolerances:

Operate the Flail Mower with tractor in low range and the PTO delivering 540 RPM

4.3 DRIVE BELT ADJUSTMENT

Loosen the Screw A and B that locks the support shaft and loosen the counter nut C.

Loosen the screws that lock the gear box on the mounting plate D.

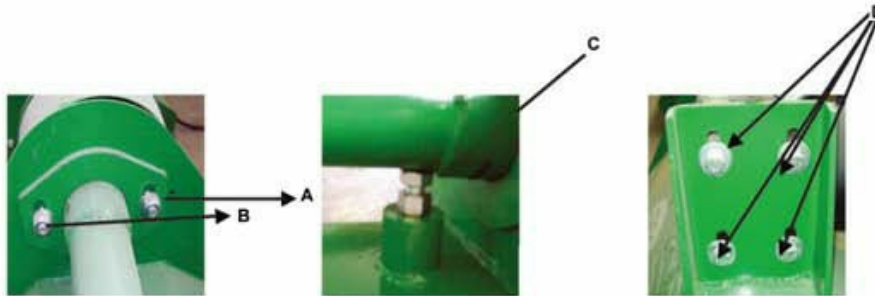

Adjust the drive belt tension. The correct belt tension is achieved when the belt can be deflected by the belt thickness about 10mm at the center point between the pulleys.

Align the gearbox so the drive shaft is parallel with the body.

Use a straight edge to make sure the belt pulleys are inline and running true. If misaligned, call your dealer or service agent for technical support.

Fit the safety covers and tighten the mounting bolts before operation.



Approx. 10mm
deflection



Align with a
Straight Edge

CHAPTER 4. PRODUCT OPERATION

4.4 STARTING UP

Before starting the machine, check and adjust the following items:

- Drive belt tension.
- Gearbox oil level.
- Grease nipples on bearings and PTO shaft.
- All bolts, nuts and screws.

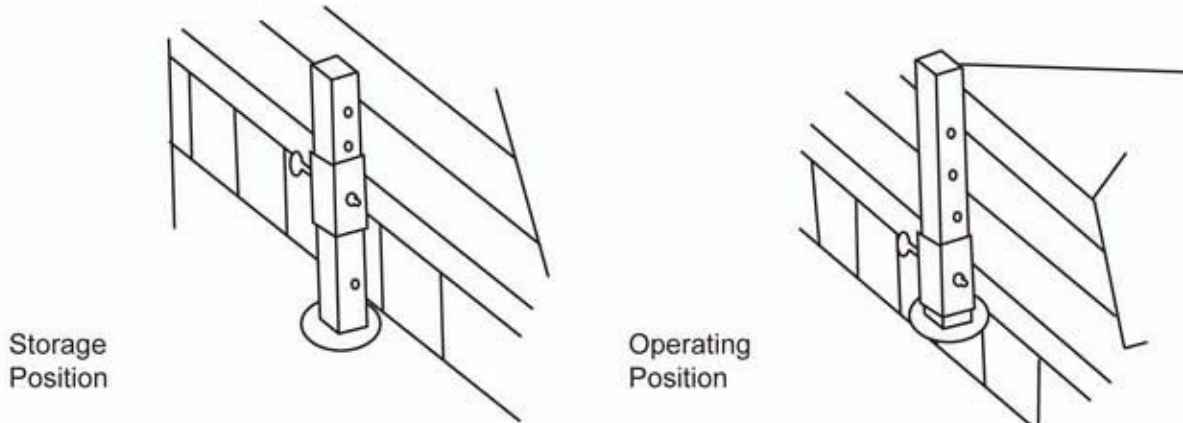

In order to keep the machine stable, lower the adjustment stand when the machine is stopped (see above drawing).

Follow all safety precaution detailed in this manual.

The machine is equipped with a standard category one, three point linkage.

Back the tractor into position in front of the flail mower. Lower the tractor hydraulic lift arms. Turn the tractor off. Maneuver the implement by hand and attach the lower link arms to the lower link pin. Ensure they are secured with lynch pin. Attach the top link to the top link bracket. Adjust the lower link sway chains to allow minimal lateral movement. Attach the PTO shaft to the Tractor PTO ensuring it has been cut to the required length.



CHAPTER 4. PRODUCT OPERATION

4.5 HYDRAULIC CONNECTION

- Switch the engine off, set the handbrake and remove the ignition key. Push the hydraulic lever to release pressure at the remotes. Connect the implement's hydraulic hoses to the remotes using the quick couplers, having checked the quick couplers are clean and in good condition.
- Start the engine and activate the hydraulics to check the connection. Check there are no oil leaks at the connection or the implement.
- Before disconnecting, stop the engine and move the remotes lever back and forth to release the hydraulic oil pressure as previously mentioned.

4.6 GREASING AND LUBRICATION

Each 4 hours of work:

- Check and tighten nuts and bolts
- Grease with lithium based grease when it is indicated by the symbol GREASE



After 50 hr of work, check and fill the gearbox to the required level, using oil type SAE 90 EP API GL4 Oil.

Each 100 hr of work:
Check the gearbox oil level. Replace as required.

CHAPTER 5. SERVICE AND MAINTENANCE

5.1 SERVICE

FLUIDS AND LUBRICANTS

1. Grease:
Use multi-purpose lithium based grease.
2. Gear Box Oil:
Use SAE 90 Gear oil.
3. Storing Lubricants:
Your machine can operate at top efficiency only if clean lubricants are used. Use clean containers to handle all lubricants. Store them in an area protected from dust, moisture and other contaminants.

GREASING

1. Use a hand-held grease gun for all greasing.
2. Wipe grease nipple with a clean cloth before greasing, to avoid injecting dirt and grit.
3. Replace broken nipples immediately.
4. If nipples will not take grease, remove and clean thoroughly. Also clean lubricant passageway. Replace nipple if necessary.

5.2 MAINTENANCE

The period recommended is based on normal operating conditions. Severe or unusual conditions may require more frequent maintenance.

HOURS OR DAILY MAINTENANCE

- Check all nuts and bolts, tighten as required.
- Check the blade and blade bolts every day and replace the damaged parts. Don't install damaged, worn and unbalanced blade. Replace sleeves as they become worn.

NOTE:

The operator should put on gloves and use suitable tools before changing blade.

- Check the oil in gearbox. Fill up to line if necessary.
- Pump grease into each grease nipple three to five times.
- Clean the implement; remove grass and mud.

SEASON MAINTENANCE

- Check the machine as in the terms of daily maintenance.
- Check the oil in gearbox; replace it if it is contaminated.
- Check the blade spindles for wear and tear. If worn, disassemble and clean them and replace them if it is necessary, grease as required.

ANNUAL MAINTENANCE

- Thoroughly Clean mud and grass off the machine.
- Check and clean blade axles. Replace seals and grease as required.
- Check all blades, replace them if they are wear-out or damaged.
- Repair or replace the side skirts back to their original size and shape. Replace damaged or broken protective devices.

CHAPTER 5. SERVICE AND MAINTENANCE

GEAR BOX MAINTENANCE

The oil should be drained out and replaced after the first 50 hours of operation. Then the oil should be changed every 250 hours, or at least once a year.

Drain oil from the gearbox thoroughly. Check and clean it. Fill with new gear oil up to the dedicated oil level.

The draining procedure is as follows: remove the draining bolt under the gear box, so that the oil drains off. After the oil is drained out, put the plug back and fill with gear oil up to the dedicated oil level.

	8hrs/ Daily			50hrs/Weekly			Annually		
Lubricate PTO Shaft	✓			✓			✓		
Lubricate Caster Wheels	✓			✓			✓		
Lubricate Blade Spindle	✓			✓			✓		
Check Gear Box Oil Level				✓			✓		
Clean Machine							✓		
Lubricate and Clean PTO Shaft Cover							✓		

PTO SHAFT MAINTENANCE

The PTO shaft is designed to telescope to allow for dimensional changes as the machine goes through its operating range. A tubular guard encloses the driving components and is designed to turn relative to the driving components. The shaft should telescope easily and the guard turn freely on the shaft at all times. Annual disassembly, cleaning and lubrication is recommended to insure that all components function as intended. To maintain the shaft, follow this procedure:

1. Remove the shaft from the machine.
2. Pull shaft apart.
3. Use a screwdriver to pry the tabs out of the sleeves on each end.
4. Pull the shaft out of the plastic tubular guard.
5. Use a solvent to clean the male and female portions of the telescoping ends.
6. Apply a light coat of grease to each end.
7. Clean the grooves on each end where the tabs are located. Clean each tab also.
8. Apply a light coat of grease to each groove.
9. Insert the shaft into its respective guard and align the slots with the groove.
10. Insert the tabs through the slots and seat in the groove.
11. Check that each guard turns freely on the shaft.
12. Assemble the shaft.
13. Check that the shaft telescopes easily.
14. Replace any components that are damaged or worn.
15. Install the shaft on the machine.

CHAPTER 5. SERVICE AND MAINTENANCE

GEARBOX MAINTENANCE

The gearbox used on the Flail mower will give many years of trouble-free service with minimal maintenance requirements. Maintain the gearbox by following this procedure:

Oil Level:

- Remove the level plug from the rear or side of the gearbox.
- Add oil through the filler plug located on top of gearbox until oil comes out of the level plug.
- Add through the level plug if required.
- If gearbox has a dipstick on filler plug, then fill to indicator mark.

IMPORTANT: Check the oil level only when the unit is cold and the machine is on the level.

5.3 STORAGE

- Clean the machine inside and out so as to avoid corrosion.
- Don't Spray water on the rolling bearing if you clean the machine with high pressure sprayer.
- Check and clean the universal joint, driving belt press roller, or replace them if they are not in good condition.
- Spread oil on all parts required.
- Recoat the parts rubbed and damaged for anti corrosion.
- Store the machine in a dry, level area.

5.4 OPERATION AFTER STORAGE

Before the machine is started up, check the following items regularly;

- Check oil level and add if required.
- Check and tighten all screws and nuts.
- Check the blade condition. Replace as required.
- Check the air hole on the gearbox. If it is blocked, clean or open the hole with compressed air.
- Don't spread oil or grease on the driving belts. If there is oil or grease on the belts, wipe the belts, to avoid slippage and premature wear.
- Check all moving parts and replace them if necessary.
- Check the protective covers are complete and operate correctly.

CHAPTER 6. TROUBLE SHOOTING

TROUBLE SHOOTING

FAILURE	CAUSE	SOLUTION	LEVEL OF DANGER
Excessive vibration of the machine	Broken flails	Replace broken flails.	Flails can be replaced by a competent operator. In the other cases, replacement must be done by specialised staff.
	Broken rotor support.	Replace rotor support with original parts.	
	Broken driving support shaft	Replace shaft support with original parts.	
	The worst: bent rotor	replace rotor with original parts	
The grass is not cut.	Broken flails.	Replace flails.	For replacement of flails, adjustment or replacement belts and fixing lock joints, see paragraph relating to maintenance.
	Belt slipping.	Adjust belt tension.	
	Broken belts.	Replace belts.	
	Pulleys slipping on shafts.	Fix pulley lock joints.	
	Broken gear box.	Repairing or replacement of gear box.	
Clogging of Hammers/ Knives	Rotor Speed is too low	Increase rotor speed	
Excessive wear of hammers/knives	Rotor speed is too high	Decrease rotor speed	
Flail Mower vibrates during works	Foreign matter stuck in between blades	Remove foreign matter	Secure flail mower on a mechanical stand before maintaining blades or rotor.
	Hammers/knives broken	Replace hammer/ knives	
	Bolts of the rotor shaft support have come loose	Lock bolts	

FMH AGL125 /145 /165 Parts List

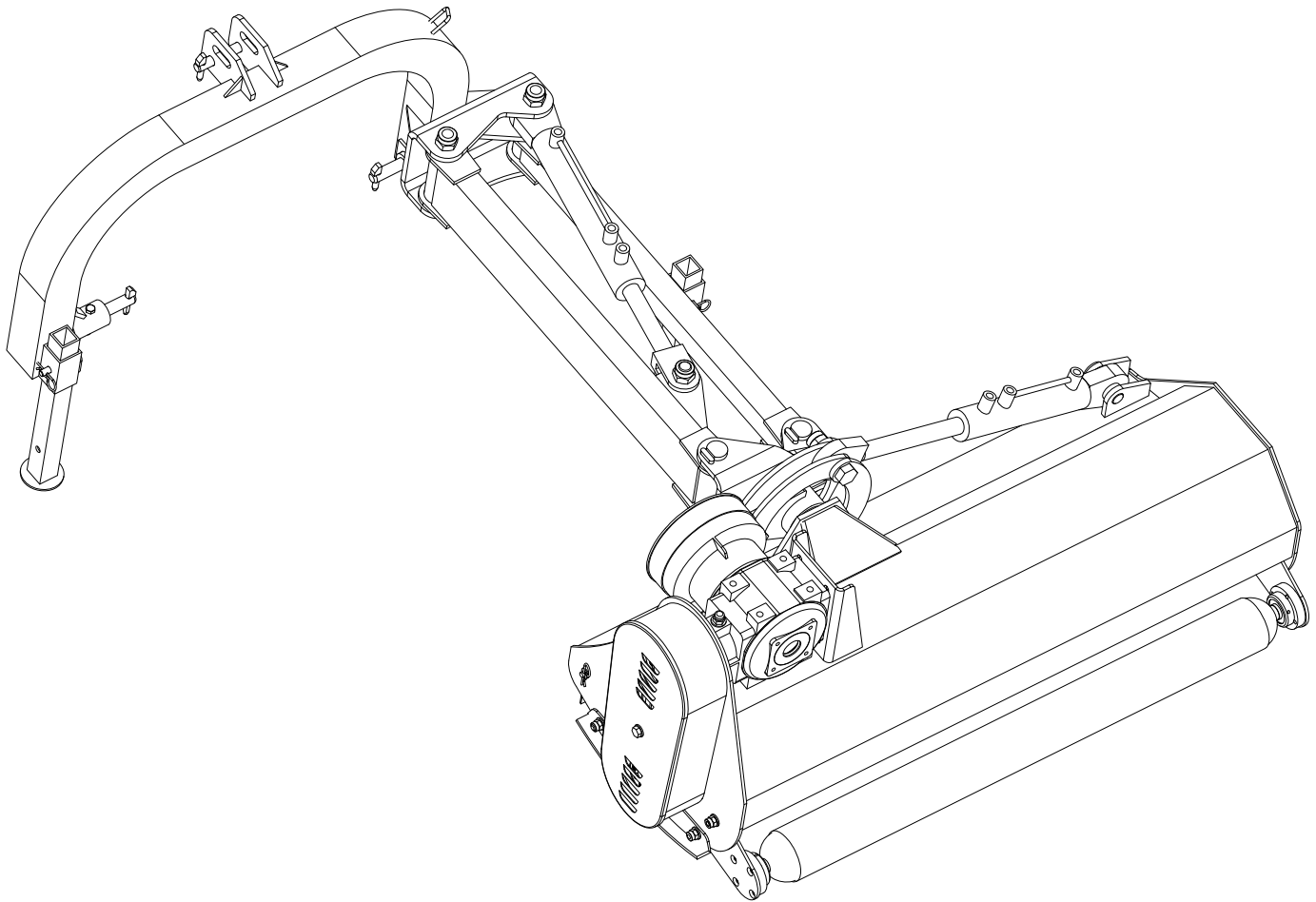

AGL125/145/165 Swing Frame Assembly Parts

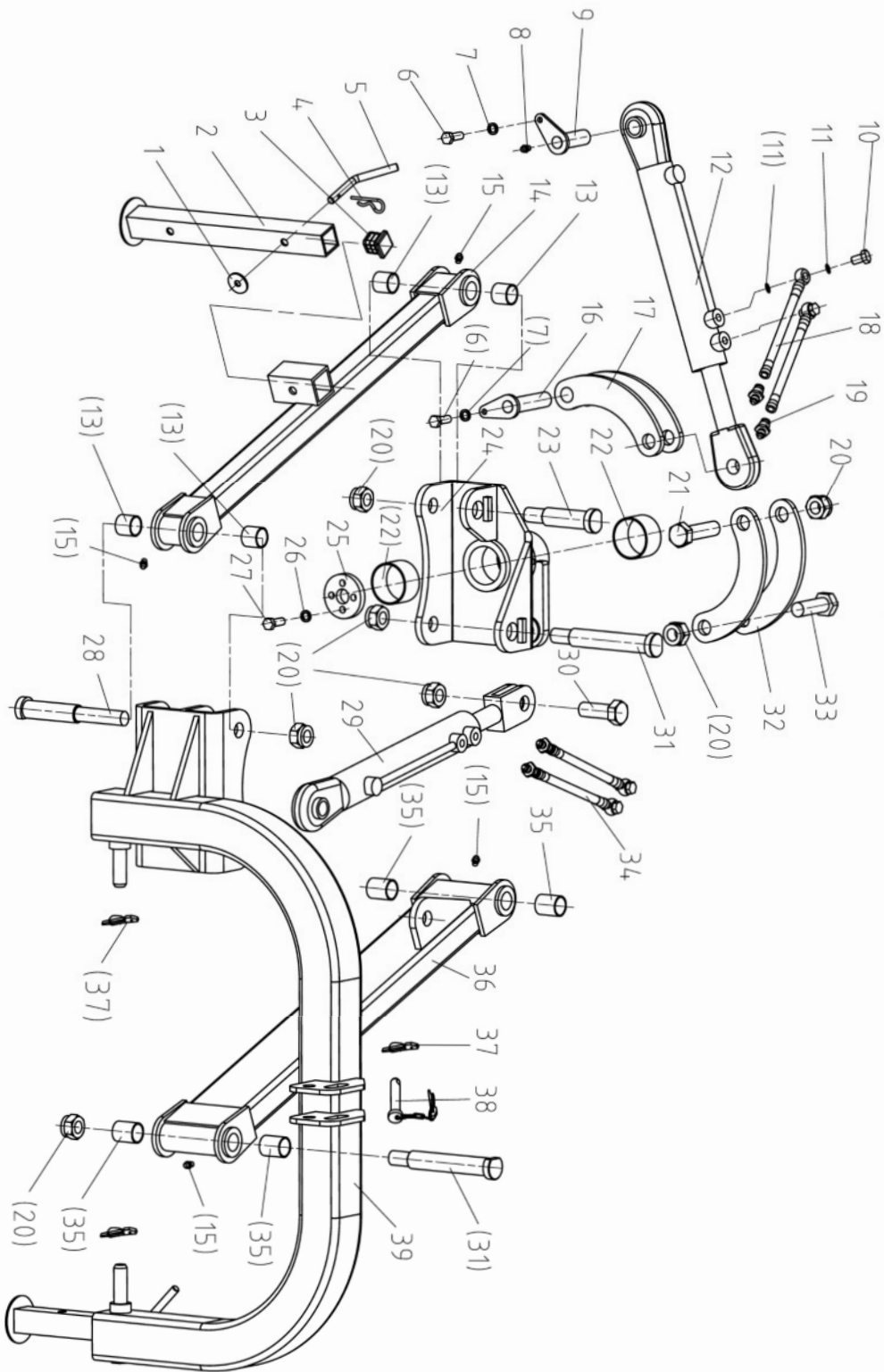

AGL125/145/165 SWING FRAME ASSEMBLY PARTS LIST

No.	Drawing No.	Name	名称及规格	Qty	No.	Drawing No.	Name	名称及规格	Qty
1	GB97.1	washer 10	平垫 10	1	21	GB5782	bolt M24X95	螺栓M24X95	1
2	AGL125.011	supporting leg	撑脚焊合件	2	22	SF65X69X38	bush 65X69X38	衬套65X69X38	2
4	AGL125.101	R pin 3.2	R销 3.2	4	23	AGL125.112	axle	销轴	1
5	AGL125.125	pin for supporting leg	撑脚销	2	24	AGL125.023	swing weldment	摆座焊合件	1
6	GB5783	bolt M8X20	螺栓M8X20	6	25	AGL125.122	fixed plate	固定板	1
7	GB93	spring washer 8	弹垫圈 8	6	26	GB93	spring washer 10	弹垫圈 10	4
8	GB1152-89	grease nipple M6X1	黄油嘴M6X1	4	27	GB5783	bolt M10X30	螺栓M10X30	4
9	AGL125.114	pin	销	1	28	AGL125.111	axle	销轴	1
10	AGL125.104	hydraulic bolt	铰接螺栓	4	29	AGL125.041	moving cylinder	移动油缸	1
11	AGL125.105	Cu washer 14.2X19X1.5	铜垫圈14.2X19X1.5	8	30	GB5782	bolt M24X65	螺栓M24X65	1
12	AGL125.040	twirl cylinder	转动油缸	1	31	AGL125.102	axle 160	销轴 160	2
13	SF30X34X28	bush 30X34X28	衬套30X34X28	4	32	AGL125.116	turn link plate	转动链板	2
14	AGL125.020	connection weldment	连接杆焊合件	1	33	GB5782	bolt M24X75	螺栓M24X75	1
15	GB1152-89	grease nipple M8X1	黄油嘴M8X1	7	34	AGL125.043	pipe for moving cylinder	移动油缸油管	2
16	AGL125.115	pin	销	1	35	SF30X34X40	bush 30X34X40	衬套30X34X40	4
17	AGL125.022	link plate weldment	链板焊合件	1	37	AGL125.109	lock pin 12	锁销 12	3
18	AGL125.044	pipe for twirl cylinder	转动油缸油管	2	38	AGL125.110	top pin	上悬挂销	1
19	QC-R1/2-M	quick connector R1/2	快换接头R1/2-阴	4	39	AGL125.012	3-point hitch weldment	悬挂框焊合件	1
20	GB/T 889.1-2000	lock nut M24	锁紧螺母 M24	7					

AGL 125/145/165 Flail Mower Assembly Parts

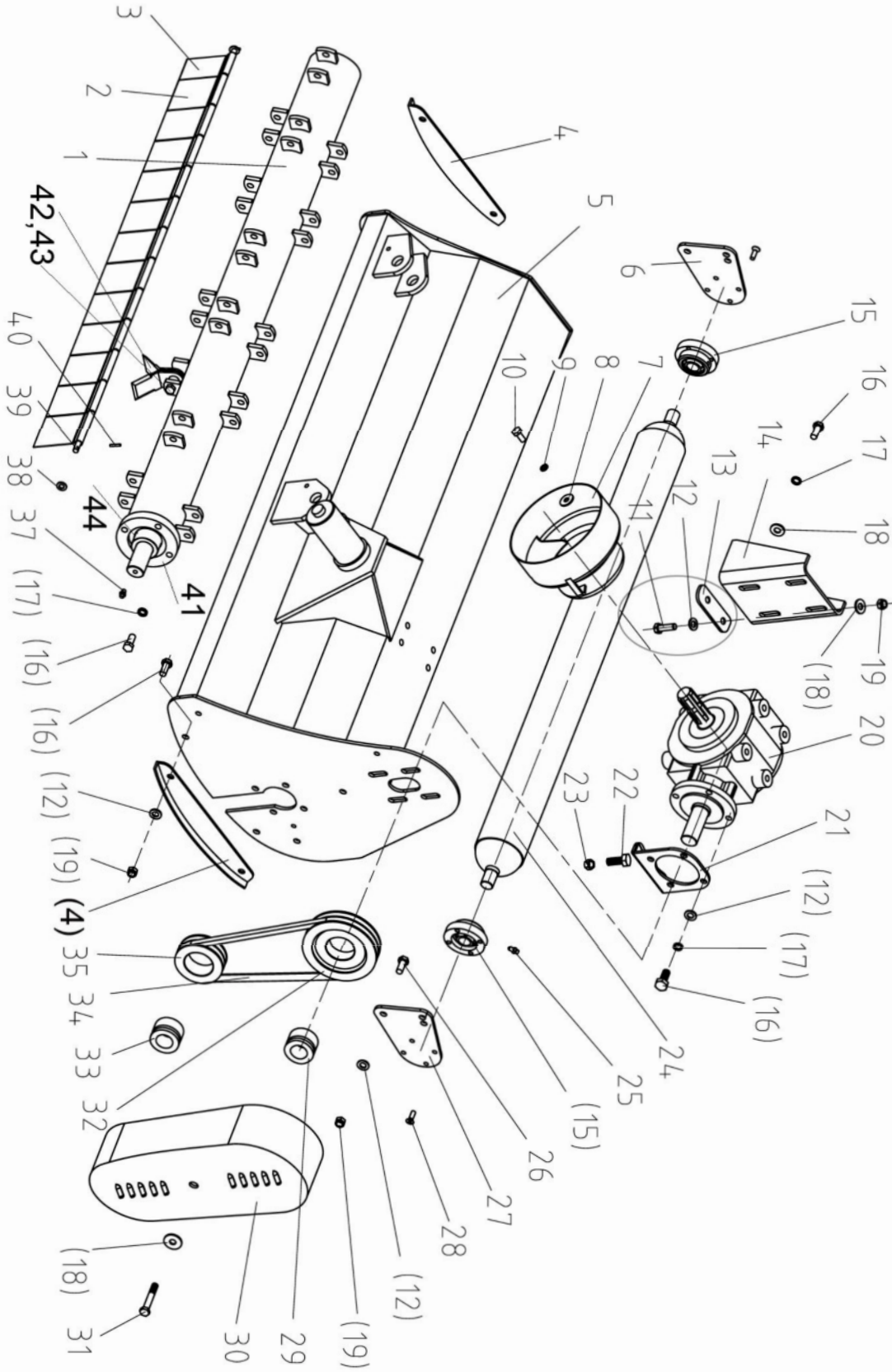

CHAPTER 7. PARTS LIST - MODEL

AGL125/145/165 Flail Mower Assembly

No.	Drawing No.	Name	零件名称	Qty	No.	Drawing No.	Name	零件名称	Qty
1	AGL125.024	blade axle weldment	刀轴焊合件	1	25	GB1152-89	grease nipper M6X1	黄油嘴M6X1	4
2	AGL125.123	fender	挡板	12	26	GB5783	bolt M12X30	螺栓M12X30	12
3	AGL125.124	narrow fender	窄挡板	1	27	AGL125.107	right roller plate	尾轮固定板-右	1
4	AGL125.015	skid weldment	滑板焊合件	2	28	GB2673-86	flat headed cap screw M8X25	内六角沉头螺钉M8X25	8
5	AGL125.021	cover weldment	罩壳焊合件	1	29	Z3-33X65	Ringfeder Z3-33X65	Z3-33X65	1
6	AGL125.106	left roller plate	尾轮固定板-左	1	30	AGL125.014	belt cover	带轮罩焊合件	1
7	AGL125.130	PTO cover	传动轴罩	1	31	GB5782	bolt M12X110	螺栓M12X110	1
8	GB97.1	washer 8	平垫圈 8	6	32	AGL125.117	bigger belt pulley	大带轮	1
9	GB93	spring washer 8	弹垫圈 8	6	33	Z3-30X60	Ringfeder Z3-30X65	涨紧套Z3-30X60	2
10	GB5783	bolt M8X20	螺栓M8X20	6	35	AGL125.120	smaller belt pulley	小带轮	1
11	AGL125.017	fitting plate with bolt	垫板焊合件	1	37	GB1152-89	grease nipper M8X1	黄油嘴M8X1	7
14	AGL125.018	gearbox mounting plate	齿轮箱座焊合件	1	38	GB97.1	washer 10	平垫圈 10	15
15	UC205	bearing asse UC205	轴承UC205	2	39	AGL125.108	stick	固定杆	1
16	GB5782	bolt M12X35	螺栓M12X35	4	40	AGL125.101	R pin 3.2	R销3.2	4
17	GB93	spring washer 12	弹垫圈 12	16	41	UC207	bearing asse UC207	轴承UC207	2
17	GB/T1154-97	V-belt VB991(B39)	V带VB991 (B39)	3	42	AGL125.121	blade (or hammer)	刀	20
18	GB97.1	washer 12	平垫圈 12	7	43	GB5782	bolt M12X80	螺栓M12X80	20
19	GB/T 889.1-2000	lock nut M12	锁紧螺母 M12	28	44	GB13871-94	oil seat FB55X80X8	油封FB55X80X8	2
20	XH50.300Z.02	gear box	齿轮箱总成	1					
21	AGL125.019	connecting plate	连接板焊合件	1					
22	GB5783	bolt M12X40	螺栓M12X40	2					
23	GB6170	nut M12	螺母 M12	3					
24	AGL125.016	roller weldment	滚筒焊合件	1					



FHM
FARMER-HELPER
MACHINERY COMPANY

Parts Request Form

Fax to 541-895-2756 or E-mail
parts@betstco.com

Name: _____

Address: _____

City State Zip: _____

Phone: _____

E-mail: _____

Model Number: _____

Serial Number: _____

Purchased From: _____

Purchase Date: _____

Item No.	Description	Qty	Price	Amount

Comments:

Farmer Helper Machinery Brand LIMITED WARRANTY

FARMER HELPER MACHINERY CO. LTD. warrants to original Purchaser that FARMER HELPER MACHINERY CO. LTD. products are free from major defects in material under normal use and service for a period of Two (2) Years from the date the product is purchased or shipped, whichever is later. Commercial use 180 days. Use at address that is not yours, is considered commercial use. Consumable, Expendable, Wear Items (Examples: Rubber & plastic parts, hydraulic hoses, belts, tires, cables, blades, tines, wedges, teeth, tips, chains, pins, brushes, filters, etc.) and cracked hydraulic pumps, bent or broken cylinder rods are not covered under this warranty. Warranty does not cover items that have been modified, damaged by abuse or usage not in accordance with design or maintenance.

FARMER HELPER MACHINERY CO. LTD.'s obligation under this warranty is to repair or replace defective product upon determination by; Betst Products, llc., 83371 Melton Rd. N., Creswell OR 97426 that Warranty Claim is Valid. Product shall be returned upon request of Betst Products, llc. Transportation charges to be prepaid by buyer. **Gasoline or diesel engines used to power FARMER HELPER MACHINERY CO. LTD. products are covered by the warranty of the appropriate engine manufacture and Purchaser must look to the engine manufacture for all issues relating to engine operation.**

Farmer-Helper Machinery nor Betst Products, llc. assumes any responsibility for labor.

PERMISSIBLE BY APPLICABLE LAW, FARMER HELPER MACHINERY CO. LTD. HEREBY DISCLAIMS ALL WARRANTIES OF ANY KIND, EITHER EXPRESS OR IMPLIED, INCLUDING, ANY IMPLIED WARRANTIES WITH RESPECT TO THE PRODUCT PURCHASED, WITHOUT LIMITING THE GENERALITY OF THE FOREGOING, FARMER HELPER MACHINERY CO. LTD. HEREBY EXPRESSLY DISCLAIMS ALL LIABILITY FOR PRODUCT DEFECT OR FAILURE, CLAIMS THAT ARE DUE TO NORMAL WEAR, PRODUCT MISUSE, ABUSE, PRODUCT MODIFICATION, IMPROPER PRODUCT SELECTION, NON-COMPLIANCE WITH ANY CODES, OR MISAPPROPRIATION. • FARMER HELPER MACHINERY CO. LTD.. MAKES NO WARRANTIES TO THOSE DEFINED AS "CONSUMERS" IN THE MAGNUSON-MOSS WARRANTY-FEDERAL TRADE COMMISSION IMPROVEMENTS ACT. THE FOREGOING EXCLUSIONS OF IMPLIED WARRANTIES DO NOT APPLY TO THE EXTENT PROHIBITED BY LAW. PLEASE REFER TO YOUR LOCAL LAWS FOR ANY SUCH PROHIBITIONS

THERE SHALL BE NO LIABILITY FOR PRODUCT LIABILITY OR LIABILITY ON THE PART OF BETST PRODUCTS, LLC. FOR ANY GENERAL, SPECIAL OR CONSEQUENTIAL DAMAGES ARISING OUT OF THE SALE OR USE OF ANY PRODUCTS SOLD BY BETST PRODUCTS, LLC OR AN AGENT THEREOF. BETST PRODUCTS, LLC. MAKES NO WARRANTIES, EXPRESS OR IMPLIED, (INCLUDING, BUT NOT LIMITED TO, ANY WARRANTY OF MERCHANTABILITY OR FITNESS OF THE PRODUCTS FOR ANY PURPOSE) WITH RESPECT TO THE PRODUCTS COVERED BY THIS AGREEMENT EXCEPT AS IN THIS PARAGRAPH OTHERWISE EXPRESSLY PROVIDED.

THIS IS THE SOLE AND ONLY WARRANTY OF FARMER HELPER MACHINERY CO. LTD. PRODUCTS. NO OTHER WARRANTY IS APPLICABLE, EITHER EXPRESSED OR IMPLIED, IN FACT OR BY LAW,

This warranty shall not be interpreted to render Betst Products, llc., or any authorized agent liable for injury or damages of any kind or nature, direct, consequential, or contingent, to person or property.

The sole and only remedy in regard to any defective products shall be the repair or replacement thereof as herein provided. Betst Products, llc., agent(s) of Betst Products, llc. shall not be liable for any consequential, special, incidental or punitive damages resulting from or caused by any such defects.

Farmer-Helper Machinery reserves the right to make improvements in design or changes in specifications at any time, without incurring any obligations to owners of units previously sold.

No one is authorized to alter, modify, or enlarge this warranty nor the exclusions, limitations, and reservation thereof.

Revised 9-20-14

WARRANTY VOID IF REGISTRATION IS NOT RECEIVED OR RECORDED ONLINE WITHIN 30 DAYS OF PURCHASE DATE OR SHIP DATE, WHICHEVER IS LATER.

FARMER HELPER MACHINERY REGISTRATION

Item _____ Model # _____ Purchase Date ____/____/____

Purchased From: _____ Gift Inv#/Order# _____

Owner Name: _____ Serial # (if Applicable) _____

Owner Address: _____

City: _____ County: _____ ST: _____ Zip Code: _____

Phone: _____ Email: _____

Acceptance of responsibility:

I (Purchaser) have read operators manual and Limited Warranty or someone has read/and explained all instructions to me. I understand this warranty does not cover any labor and that all disputes will be settled by binding arbitration. Binding arbitration is conducted by the Better Business Bureau (BBB) located at 4004 SW Kruse Way Place Ste 375 Lake Oswego OR 97035 or the current BBB location closest to Betst Products, I acknowledge my Limited Warranty is void if any attempt to repair or replace defective parts has been made by unauthorized personnel. I acknowledge receipt of my Operators Manual and have read the Safe Operation Section. I acknowledge understanding maintenance and safe operation requirements, item specifications, operation, controls, and storage requirements. I **understand that I alone am responsible for proper maintenance, care and safe operation of this Value-Leader item.**

I (Purchaser) agree that persons not familiar with the operation of this item should not be allowed to use it. Children especially should not operate or be near Power Products when in use. ANYONE OPERATING FARMER-HELPER PRODUCTS SHOULD HAVE READ OPERATIONS MANUALS AND SAFETY MANUALS.

Owners Signature: x _____ Date: ____/____/____

You must sign this warranty and mail or fax copy to Betst Products, 83371 Melton Rd N.#3, Creswell OR 97426. If you prefer you may complete your registration on line. This warranty is not effective unless the Purchaser completes Registration and Warranty Form within 30 days of purchase or ship date whichever is later.

Fax to 1-904-216-2059

NOTE: We may refuse warranty of any kind unless Betst Product, llc., receives a completed, legible and signed warranty registration. It is the responsibility of the purchaser to assure that registration document is received by Betst Products, llc..

Fax to 1-904-216-2059

Revised 9-20-14

2 YEAR EXTENDED WARRANTY & REGISTRATION

Farmer Helper Machinery Branded Products

2 YEAR EXTENDED WARRANTY

2 Year Extended Warranty amends to original Recorded Manufacturers Warranty Registration the time period of described coverage. Extended Warranty does not apply to Consumable and Expendable Items as described in Product Warranty Registration.

This Amendment does not affect any other part of recorded Warranty Registration or Policy. This Warranty Extension is the soul responsibility of Betst Products, llc.

No one is authorized to alter, modify, or enlarge this addtion to the original manufacturers recorded warranty registration.

EXTENDED REGISTRATION & PAYMENT MUST BE RECEIVED WITHIN 30 DAYS OF PURCHASE DATE

EXTENDED WARRANTY REGISTRATION

Product & Model # : _____

Serial #: _____

Owner Name: _____

Betst Products Invoice # _____

Acceptance of responsibility:

I (Purchaser) have Read and understand the Extended Warranty or someone has read/and explained all the above to me. I understand this extended warranty does not cover any labor. I have filed my Original Warranty Registration and fully understand my requirements. I **understand that I alone am responsible for proper maintenance, care and safe operation of this tractor implement.**

I (purchaser) also understand that persons not familiar with the operation of this equipment should not be allowed to use it. Children especially should not operate or be near equipment. ANYONE OPERATING EQUIPMENT SHOULD HAVE READ ALL EQUIPMENT OPERATIONS MANUALS AND SAFETY MANUALS..

Owners Signature: x _____

Date: _____

You must sign this extended warranty and email to support@betstco.com or Fax to 1-305-397-1780 or mail copy to Betst Products, 83371 Melton Rd N.#3, Creswell OR 97426. This extended warranty is not effective unless the Purchaser faxes or mails this Registration Form within 30 days of purchase. NOTE: The manufacturer may refuse warranty of any kind unless Betst Products receives a completed, legible and signed extended warranty registration. It is the responsibility of the purchaser to assure that this registration document is received by Betst Products.

To Make Payment for Extended Warranty Call: 1-877-876-7895

Revised 9-20-14